

LIGHT ID	MOUNTING HEIGHT (FT)	ORIENTATION (DEG)	TILT (DEG)
LP1	25	111	0
LP2	25	48	0
LP3	25	345	0
LP4	25	195	0
LP5	25	245	0
LP6	25	7	0
LP7	25	245	0
LP8	25	244	0
LP9	25	245	0
LP10	25	80	0
LP11	25	165	0
LP12	25	240	0
LP13	25	190	0
LP14	25	112	0
LP15	25	245	0
LP16	25	318	0

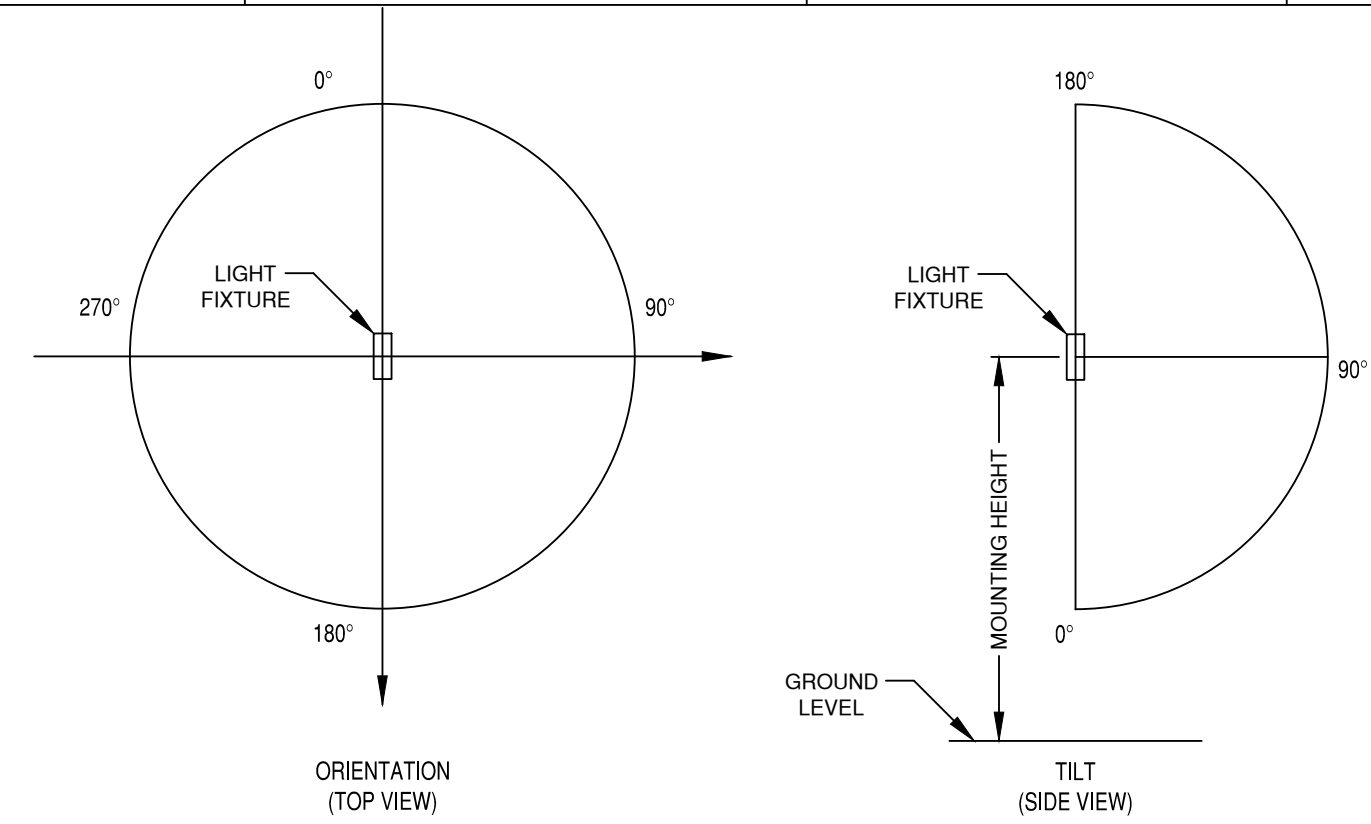

LEGEND

- INVERTER SKID
- BATTERY
- AUXILIARY SKID
- ACCESS ROADS
- LIGHT POLE (LPX)
- BESS FENCE
- PROJECT BOUNDARY

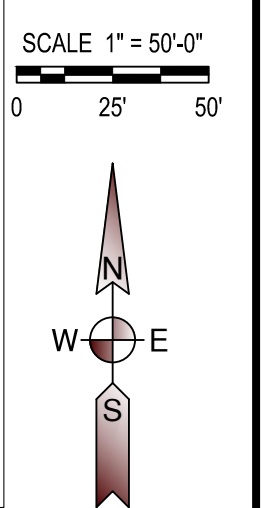

ALCAZAR BESS PROJECT

ULSTER COUNTY, NEW YORK

REV.	DATE	DESCRIPTION	BY
A	03/26/2025	ISSUED FOR PERMIT	RG



911455 EL CAMINO REAL, SUITE 160 SAN DIEGO, CA 92130



MAD83 NEW YORK STATE PLANES, EAST ZONE, US FOOT

THIS DRAWING IS PRELIMINARY AND IS NOT TO BE USED FOR CONSTRUCTION. FOR REVIEW PURPOSES ONLY & SUBJECT TO CHANGE

NY ENGINEERING, PLLC

PROJECT NUMBER: 24.04181
 DESIGN BY: NR
 DRAWN BY: NR
 APPROVED BY: RG
 FIRM REG NO: 022381

BATTERY ENERGY STORAGE SYSTEM LIGHTING PLAN

DRAWING NUMBER: **ABP-COL-L1** REVISION: **A**